

Forging Our Own Way For Over 70 years

MKS is a family owned & operated business that has been manufacturing pedals in our own factory in Japan since being founded over 70 years ago. The cold forging process we began using 65 years ago allows us to make precision parts that are not only stronger, but also more precise than hot forged parts, with less waste.

MKS has been perfecting our heat treatment and quality control

processes over the last 70 years. Heat treating metals after forming hardens the parts, improving wear resistance, tensile strength, and fatigue strength. As a result of our expertise we are able to consistently produce extremely durable axles and structural components such as cups and cones.

Utilizing Unique Materials

MKS uses ADC-6 alloy for our die-casting, instead of the common ADC-12 alloy. Although the material is very difficult to cast, we believe ADC-6 is a superior material for pedal bodies and have been able to master working with it over the decades. When compared to more common alloys ADC-6 anodizes remarkably well, and is extremely impact and corrosion resistant.

The Only Pedals Authorized For Keirin

Professional bicycle racers in the Japanese Keirin can only use parts that have passed the strict standards set by the Japan Keirin Autorace Foundation (commonly referred to as NJS). Only MKS is certified to supply pedals for Keirin bicycle racing. As of 2023 about 2,400 Professional cycles are racing the Keirin on MKS Pedals!

Every Pedal Is Hand Adjusted

All pedals are hand adjusted, and our top models are hand assembled one at a time. For our high quantity pedals we developed a custom assembly robot that reliably assembles pedals. Thorough controls create a rideable pedal, but we still manually adjust and inspect every pedal we make.

Benefiting From Diversification

Due to our expertise in forging, pressing, heat treatment, polishing, welding, and assembly we have become involved in manufacturing of automotive parts. In 2004 we obtained ISO 90001 certification (updated to ISO 90001-2015 in 2017). This certification has benefited pedal production as we now follow international standards, ensuring we are making safe, secure and reliable parts.

MKS®

58TH Edition



MKS®

MIKASHIMA INDUSTRIAL CO., LTD

www.mkspedal.com

www.facebook.com/mkspedal

www.instagram.com/mkspedal

www.twitter.com/mkspedal

359-1166, 1738 Kojiya, Tokorozawa, Saitama, Japan

TEL:04-2948-1261

MIKASHIMA INDUSTRIAL CO., LTD

2024

Finest Sealed Bearings

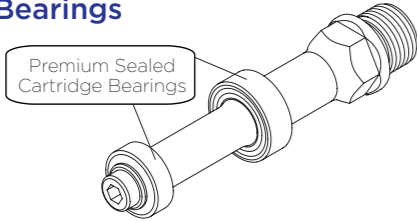

Rotational Performance ★★★★★
Weight to Strength ★★★★★
Maintainability ★★★

Hand assembled one at a time.
Our Fastest Bearing System.

Triple Sealed Bearings

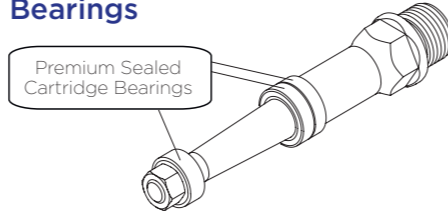

Rotational Performance ★★★★★
Weight to Strength ★★★★★
Maintainability ★★★

Remarkably fast, yet strong and durable.

High Polish Cup & Cone

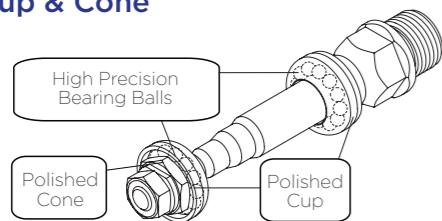

Rotational Performance ★★★★★
Weight to Strength ★★★★★
Maintainability ★★★★★

Our highest quality user serviceable bearing.

Cup & Cone

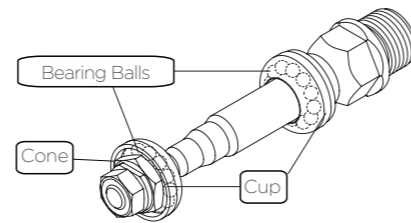
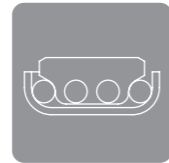

Rotational Performance ★★★★★
Weight to Strength ★★★★★
Maintainability ★★★★★

Simple, durable, proven.
Easy to maintain.

Sealed & Bushing

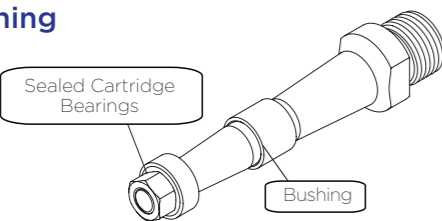

Rotational Performance ★★★
Weight to Strength ★★★★★
Maintainability ★★★

Compact, Strong, and Light.

Ezy



Easy of use ★★★★★
Weight ★★★★★
Strength ★★★★★

Ezy Superior



Easy of use ★★★★★
Weight ★★★★★
Strength ★★★★★



For space-saving
in and outside of home



For quick changes
of bicycles



For use on
Mass Transit

Ezy

Eight models of MKS pedals are available with our patented quick release pedal system, named **Ezy**.

Once installed, the Ezy system allows for safe, rapid, and toolless removal of pedals for travel or storage. Particularly popular as an upgrade for folding bicycles, those who take their bikes on mass transit, or travel bikes with coupler systems our Ezy system can dramatically improve ride quality while saving space. **The Ezy system requires a stopper be installed to lock the system when riding.**



- UX-D Ezy
- US-S Ezy
- Compact Ezy
- CYGMA Ezy
- MT-E Ezy
- PROMENADE Ezy
- UB-LITE Ezy
- AR-2 Ezy
- UX-D one sided Ezy
- PROMENADE one sided Ezy
- CYGMA one sided Ezy
- Compact one sided Ezy

Ezy Superior

Thirteen models of MKS pedals are available with our patented second generation quick release pedal system named **Ezy Superior**.

Once installed, the Ezy Superior system allows for safe, rapid, and toolless removal of pedals for travel, or storage. Particularly popular as an upgrade for folding bicycles, those who take their bikes on mass transit, or travel bikes with coupler systems our Ezy superior system can dramatically improve ride quality while saving space.



- Allways Ezy Superior**
- US-L Ezy Superior**
- Sylvan Touring Next Ezy Superior**
- Sylvan Stream Next Ezy Superior**
- Sylvan Road Next Ezy Superior**
- Sylvan Track Next Ezy Superior**
- TOURING-LITE Ezy Superior**
- Urban Platform Ezy Superior**
- LAMBDA Ezy Superior**
- GAMMA Ezy Superior**
- Pretzel Ezy Superior**
- ESPRIT Ezy Superior**
- Panamax Ezy Superior**
- Sylvan Touring Next One Sided Ezy Superior**
- TOURING-LITE One Sided Ezy Superior**

Clip Compatible



Clip Recommended



1/2" Thread Optional



Clipless Pedal



Folding Pedal



NJS Approved



FD-7 WIDE

The FD-7 WIDE is the biggest folding pedal in MKS history! It uses the folding mechanism of the FD-7 (→P16), but extends the tread length to 109.7 mm. The protrusions on the outer and inner sides of the pedal body provide good grip even when riding on rough surfaces or in the rain. The robustness has already been proven by the FD-7 and these long-lasting pedals are the perfect upgrade for your folding bike.

- To fold the pedals:
1. Push the button in the center of pedal body
 2. Pull or push the pedal body in the direction of your choosing
- To Unfold the pedals:
1. Push the cage up until you hear a satisfying click.



BODY	STEP	WEIGHT	COLOR
Alloy	Double Sided	562g	<input type="checkbox"/> Silver <input checked="" type="checkbox"/> Black

SYLVAN GORDITO

The name Gordito comes from a South American Spanish language "term of endearment" that translates to chubby, but is used like the word darling. The Gordito pedal is large and lovable. Maintaining the same width of the Sylvan touring, we have increased the length of the pedal body allowing for a large comfortable platform for the rider to firmly rest their feet. This pedal is ideal for those looking for a comfortable ride, as well as those with large legs or shoes. Like the Sylvan touring, the cage plate tooth profile is grippy, but not particularly aggressive.

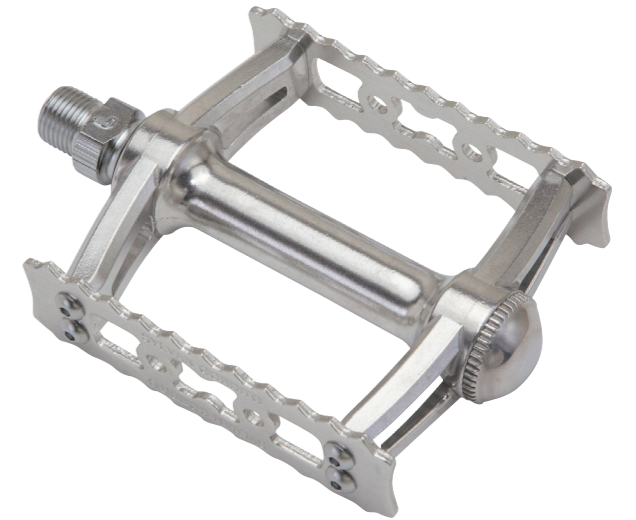

BODY	STEP	WEIGHT	COLOR
Alloy	Double Sided	430g	<input type="checkbox"/> Silver <input checked="" type="checkbox"/> Black

PRETZEL / EZY SUPERIOR

Following on from the GAMMA gravel and mixed surfaces pedal (→P10), MKS released the Pretzel, incorporating C-shaped die-castparts for a wider tread surface.

Eight M4 spike pins per side are placed for grip. Maximum thickness of 28 mm including spike pins and 23 mm in the center of the pedal; the concave shape secures the foothold. With built-in reflectors, it is suitable for city riding as well as gravel riding.

Available in two colors: silver with barrel polish and black with electrodeposition coating.



BODY	STEP	WEIGHT	COLOR
Alloy	Double Sided	530g Ezy Superior 593g	<input type="checkbox"/> Silver <input checked="" type="checkbox"/> Black



SEAHORSE

The "Seahorse" is named after its uniquely curved shape.

The pedal body is offset 4 mm forward from the centre of the axle, allowing the shoe sole to fit the step well. Protrusions on the front and rear edges provide good grip. Although the tread is large at 72 mm in width and 93 mm in length, it is light weight at 340 grams. The body has four 4.2 mm x 26 mm horizontal holes for pedal strap. Front and rear reflectors improve night visibility.

Available in two colors: silver with barrel polish and black with electrodeposition coating.



BODY	STEP	WEIGHT	COLOR
Alloy	Double Sided	340g	<input type="checkbox"/> Silver <input checked="" type="checkbox"/> Black



THE SYLVAN LINE

Since its release in 1979 the Sylvan has been MKS's bestselling pedal line. Over 40 years of continuous production have validated the Sylvan's popularity, timeless styling, and longevity. The Sylvan line currently comes in three series: Sylvan, Sylvan NEXT, and Sylvan NEXT Ezy Superior.

The Sylvan line has been designed to be used on all pavement or path bicycles, and we offer four unique models depending on your intended use in three series.



Sylvan Road

is built around a compact pedal body and features a single-sided one-piece cage plate that is curved around the end cap of the pedal, that allows for more clearance when cornering than the touring while protecting the axle. The cage plate tooth profile is essentially flat, so we recommend toe clips and straps with this pedal.



Sylvan Track

shares the same compact pedal body as the Road, but has a shorter two-piece single-sided cage plate allowing for even more ground clearance than the Sylvan road. The Sylvan Track is designed to be used on the steep banking of a velodrome, but is also at home on the road. The cage plate tooth profile is similar to the road, and we recommend toe clips and straps with this pedal.

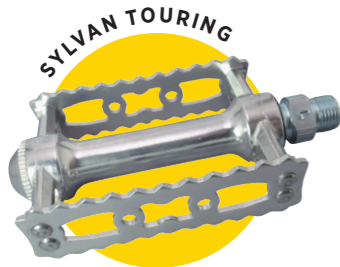

Sylvan Touring

pedal has the largest step area in the line, offering various foot position over a 94 x 63mm area to prevent fatigue. While the pedal is double sided, it also accepts toe clips and straps to prevent slipping. This pedal works well for a wide variety types of shoes, as the cage plate tooth profile isn't particular aggressive. As the name suggests, this pedal is awesome for touring.



Sylvan Stream

is about the same size as the Track, but is double-sided and the cage plate has an aggressive tooth profile to provide grip in any shoe. Similar the Touring, the Stream also accepts toe clips and straps to prevent slipping. We recommend the Sylvan Stream as a standard pedal for urban riding.

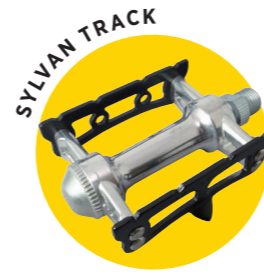

Sylvan Series

are our classic pedals, featuring cold forged Japanese steel spindles, high grade alloy pedal bodies with riveted cage plates. All Sylvan pedals accept toe clips and straps. Sylvan series pedals spin on the MKS hand-adjusted cup and cone bearing system. Sylvan pedals are finished with a silver anodized pedal body around a chrome plated axle, and are available with silver or black cage plates. The Sylvan series has remained a steadfast go-to for cyclist over the last four decades.



Sylvan NEXT Ezy Superior

Additionally, all of the Sylvan NEXT series pedals are available with our patented Ezy Superior quick release pedal system, known as the Sylvan NEXT Ezy Superior. Once installed, the Ezy Superior system allows for safe, rapid, and toolless removal of pedals for travel or storage. Particularly popular as an upgrade for folding bicycles, those who take their bikes on mass transit, or travel bikes with coupler systems our Ezy superior system can dramatically improve ride quality while saving space. The Sylvan NEXT Ezy Superior pedals have all of the benefits of the Sylvan NEXT listed above, except the chromed spindles have been replaced with our Ezy superior spindles.



Sylvan NEXT Series

is our new series of premium pedals, upgrading the bearings and cage plate fastening systems while maintaining the Sylvan's traditional styling. The Sylvan NEXT series uses our Triple Sealed Cartridge Bearings that provide a remarkably smooth and maintenance-free rotation at a lighter weight than the Sylvan series. The

low drag bearing improves pedaling efficiency, making the Sylvan NEXT series suitable for long distance riding. While the Sylvan cage plates are riveted, and Sylvan NEXT uses screws to fasten the plate to the pedal body making them replaceable- or customizable.

To match the improved performance, we have upgraded the finish of the Sylvan NEXT series. While the Sylvan series has silver or black anodized step plates and natural silver or painted black pedal body, the Sylvan NEXT is available in high polished chrome plated step plates and mirror finished pedal body, or black painted step plates and pedal body. The highly polished chrome plated step plates have not only high quality finish, but also have extremely strong anti-corrosive character, providing enhanced durability to sea breeze and rain.

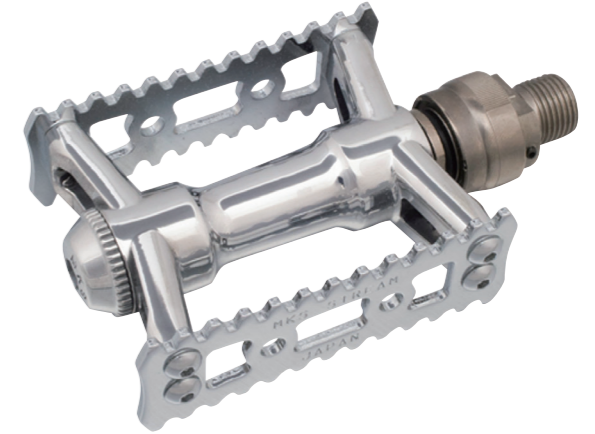

Name	Bearing System	Weight Per Pair	Black JAN Code	Silver JAN Code
Sylvan Touring	Cup and Cone	391g	4560369001095	4560369001088
Sylvan Road	Cup and Cone	360g	4560369001057	4560369001040
Sylvan Track	Cup and Cone	343g	4560369001071	4560369001064
Sylvan Stream	Cup and Cone	343g	4560369001118	4560369001101
Sylvan Touring NEXT	Triple Sealed Bearing	338g	4560369004492	4560369004300
Sylvan Road NEXT	Triple Sealed Bearing	330g	4560369004522	4560369004331
Sylvan Track NEXT	Triple Sealed Bearing	318g	4560369004546	4560369004355
Sylvan Stream NEXT	Triple Sealed Bearing	318g	4560369004560	4560369004423
Sylvan Touring NEXT Ezy Superior	Triple Sealed Bearing	393g	4560369004508	4560369004317
Sylvan Road NEXT Ezy Superior	Triple Sealed Bearing	385g	4560369004539	4560369004348
Sylvan Track NEXT Ezy Superior	Triple Sealed Bearing	373g	4560369004553	4560369004362
Sylvan Stream NEXT Ezy Superior	Triple Sealed Bearing	373g	4560369004577	4560369004430
Sylvan Touring NEXT Ezy Superior (1 sided Quick Release)		364g	Call for Details	
Ezy Superior Adapter (for additional Bikes)			4560369000043	
Sylvan pedals are also available with 1/2" spindles. Please contact the sales department for more information.				

SYLVAN ROAD

is a quill style pedal built around a compact body and features a single-sided one-piece cage plate that is curved around the end cap of the pedal, that allows for more clearance when cornering than the Sylvan Touring while protecting the axle.



BODY	STEP	WEIGHT	COLOR
Alloy	Single Sided	360g	■ Silver ■ Black

SYLVAN TRACK

features a short two-piece single-sided cage built around a compact pedal body that allows for ample ground clearance when cornering. The Sylvan Track is designed to be used on the steep banking of a velodrome, but is also at home on the road.

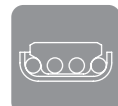

BODY	STEP	WEIGHT	COLOR
Alloy	Single Sided	343g	■ Silver ■ Black

SYLVAN TOURING

has remained a steadfast go-to for cyclist over the last four decades. Offering the widest step area in the Sylvan line, this high value and rebuildable pedal works well for a wide variety types of shoes and situations.



BODY	STEP	WEIGHT	COLOR
Alloy	Double Sided	391g	■ Silver ■ Black

SYLVAN STREAM

is a double-sided pedal about the same size as Sylvan Track. The cage plate has an aggressive tooth profile to provide grip in any shoe. We recommend the Sylvan Stream as the standard pedal for urban riding.



BODY	STEP	WEIGHT	COLOR
Alloy	Double Sided	343g	■ Silver ■ Black

SYLVAN ROAD NEXT / EZY SUPERIOR

is an upgraded version of our hit the Sylvan Road features an improved bearing system and finish. Also available with our EZY superior quick release axle system.



BODY	STEP	WEIGHT	COLOR
Highly Polished Alloy	Single Sided	330g Ezy Superior 385g	■ Silver ■ Black

SYLVAN TRACK NEXT / EZY SUPERIOR

is an upgraded version of the Sylvan Track features an improved bearing system and finish. Also available with our EZY superior quick release axle system.

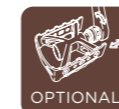

BODY	STEP	WEIGHT	COLOR
Highly Polished Alloy	Single Sided	318g Ezy Superior 373g	■ Silver ■ Black

SYLVAN TOURING NEXT / EZY SUPERIOR

is an upgraded version of our hit the Sylvan Touring featuring an improved bearing system and finish. Available with our EZY Superior quick release axle system making this pedal perfect for touring bikes!



BODY	STEP	WEIGHT	COLOR
Highly Polished Alloy	Double Sided	338g Ezy Superior 393g	■ Silver ■ Black

SYLVAN STREAM NEXT / EZY SUPERIOR

is an upgraded version of the Sylvan Stream features an improved bearing system and finish. Also available with our EZY superior quick release axle system which is perfect for folding bikes!



BODY	STEP	WEIGHT	COLOR
Highly Polished Alloy	Double Sided	318g Ezy Superior 373g	■ Silver ■ Black

ALLWAYS / EZY SUPERIOR

We set out to design a pedal that can be used for all types of cycling. With a large platform, replaceable pins, our triple sealed bearing, and lightweight body the Allways is unlike anything else on the market!

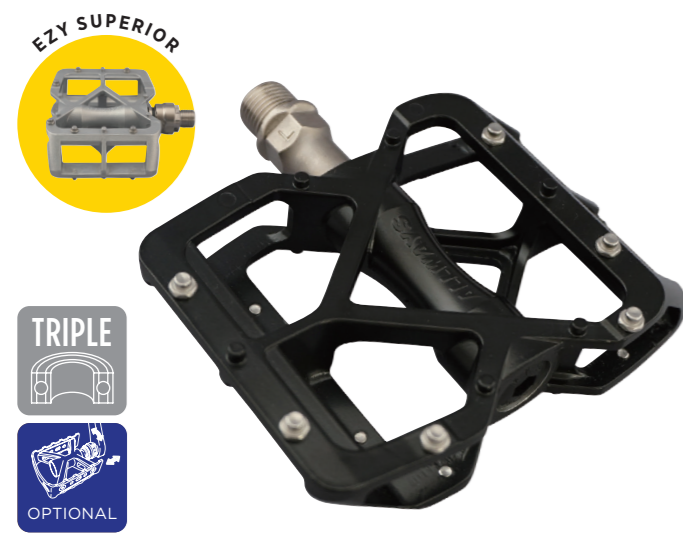

BODY	STEP	WEIGHT	COLOR
Alloy	Double Sided	381g Ezy Superior 436g	■ Silver ■ Black

LAMBDA / EZY SUPERIOR

is a unique double-sided platform pedal designed in conjunction with Rivendell Bicycle Works. The large C-shaped step blocks feature a octopus sucker inspired dimple to provide grip.



BODY	STEP	WEIGHT	COLOR
Alloy	Double Sided	420g Ezy Superior 483g	■ Silver ■ Black

COMPACT / EZY

At 233 grams a pair this is our lightest pedal. Using a sealed bearing and bushing bearing helps keep the weight down while keeping the pedal impact resilient. The EZY version is perfect for folding bikes.



BODY	STEP	WEIGHT	COLOR
CNC milled Extruded Alloy	Double Sided	233g Ezy 303g	■ Grey ■ Black

CYGMA / EZY

Recommended for city riding and light touring. Although CYGMA is made of aluminium casting, but the weight is almost the same as the extruded and CNC-machined Compact.



BODY	STEP	WEIGHT	COLOR
Alloy	Double Sided	240g Ezy 310g	■ Silver

GAMMA

Co developed with Rivendell Bicycle the GAMMA is our mixed surface pedal. Built around the proven pedal body used on the LAMBDA paired with a new step block. The Gamma has eight replaceable anti-slip grip pins per side to provide an outstanding hold on a remarkably stable pedal.



BODY	STEP	WEIGHT	COLOR
Alloy	Double Sided	450g Ezy Superior 513g	■ Silver ■ Black

RMX

We designed the RMX for riding around town in sneakers. The square shape evenly distributes the weight over a larger surface area making the RMX gentle on your feet This pedal pairs well with flat soled shoes such as vans, and features an angled low-profile tread to provide stability without damaging shoes.

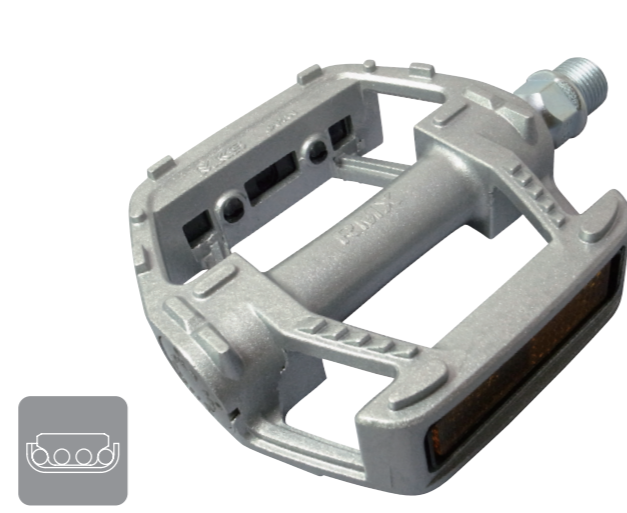

BODY	STEP	WEIGHT	COLOR
Alloy	Double Sided	384g	■ Cosmic Silver

CT-LITE

is our entry level road pedal built around our cup and cone bearing system, and is offered in anodized silver or black paint. It is compatible with all of our toe clips, and is an excellent quality for the cost.



BODY	STEP	WEIGHT	COLOR
Alloy	Double Sided	343g	■ Silver ■ Black

IC-LITE

is an entry level road bike pedal featuring a reflector. If you don't wish to have a reflector on your bicycle, please consider our CT-Lite which is a similar pedal without a reflector.



BODY	STEP	WEIGHT	COLOR
Alloy	Double Sided	365g	■ Silver ■ Black

PROMENADE / EZY

uses replaceable aluminum side plates. It uses an aluminum body with a compact design and is approximately 85 grams lighter than SYLVAN TOURING. The contact surface between the side plate and the shoe is flat, making it difficult to damage the shoe.



BODY	STEP	WEIGHT	COLOR
Alloy	Double Sided	304g Ezy 355g	■ Titanium ■ Black

UB-LITE / EZY

The PROMENADE side plate is designed to be integrated into a U-shape, ensuring a wide stepping width. It is approximately 75 grams lighter than SYLVAN TOURING. Reduces the impact on the pedal body in the event of a fall.



BODY	STEP	WEIGHT	COLOR
Alloy	Double Sided	314g Ezy 365g	■ Silver ■ Black

TOURING-LITE

The sliding part of the bearing is polished and uses chrome balls with excellent roundness and hardness. With regular maintenance, it can be used semi-permanently.



BODY	STEP	WEIGHT	COLOR
Alloy	Double Sided	320g	■ Silver ■ Black

TOURING-LITE SHORT / EZY SUPERIOR

The sliding part of the bearing is polished and uses chrome balls with excellent roundness and hardness. With regular maintenance, it can be used semi-permanently. This is a model with a side plate 7mm shorter than the TOURING-LITE mentioned above.



BODY	STEP	WEIGHT	COLOR
Alloy	Double Sided	312g Ezy Superior 375g	■ Silver ■ Black

ESPRIT / EZY SUPERIOR

Blockish in form the 1-piece cage and body are more angular than a traditional pedal. The design moves the pedal body further away from the crank allowing for flex providing a smoother ride on rough roads.



BODY	STEP	WEIGHT	COLOR
Alloy	Double Sided	352g Ezy Superior 415g	■ Titanium

MT-E / EZY

Aluminum die-cast pedals designed to be used with toe clips and straps. Although it is intended to be treaded on one side, there is also an auxiliary tread surface on the back for when the clip is not used.



BODY	STEP	WEIGHT	COLOR
Alloy	Double Sided	323g Ezy 374g	■ Silver ■ Black



GR-9

provides a generous platform that's great for soft sole shoes, while keeping a small form. Designed with city or touring riding in mind, some rides with larger shoes may prefer the GR-10.



BODY	STEP	WEIGHT	COLOR
Alloy	Single Sided	299g	■ Silver ■ Black

GR-10

provides a generous platform that's great for soft sole shoes, while keeping a small form. Designed with city or touring riding in mind, some rides with smaller shoes may prefer the GR-9.



BODY	STEP	WEIGHT	COLOR
Alloy	Single Sided	340g	■ Silver ■ Black

SUPREME

We takes no shortcuts and focus on precision when building our NJS pedals. Our most skilled employees assemble and adjust the SUPREME pedal one at a time. The SUPREME was designed and built for professional track racing, the certification is stamped onto every pedal using the NJS mark.



BODY	STEP	WEIGHT	COLOR
Highly Polished Alloy	Single Sided	294g	■ Silver ■ Black

RX-1

is our lightest Track racing pedal. Designed and built for professional track racing the NJS certification is stamped onto every pedal. Since its release in 1985 the RX-1 has been a favorite on the Japanese professional track racing circuit.



BODY	STEP	WEIGHT	COLOR
Highly Polished Alloy	Single Sided	281g	■ Black

URBAN PLATFORM / EZY SUPERIOR

could be considered an upgraded version of the GR series pedals. The Urban Platform features ridges to provide grip on the exterior edges of the pedal body and along the axle line.



BODY	STEP	WEIGHT	COLOR
Alloy	Single Sided	310g Ezy Superior 365g	■ Silver ■ Black

AR-2 / EZY

is a modern quill style road pedal. The unique asymmetrical cage plate design allows for additional inboard clearance at the quill for wide shoes when compared other quill pedals.



BODY	STEP	WEIGHT	COLOR
Alloy	Single Sided	293g Ezy 344g	■ Silver ■ Black

ROYAL NUEVO

is a lightweight, super smooth turning, classically styled track pedal that's made and approved for the velodrome, but is also a great fit for a classic bike and fixed gear builds. The short axle length helps reduce pedal flex and allows the rider to keep a narrow stance width to provide clearance on a track's banking.



BODY	STEP	WEIGHT	COLOR
Highly Polished Alloy	Single Sided	297g	■ Satin-Silver

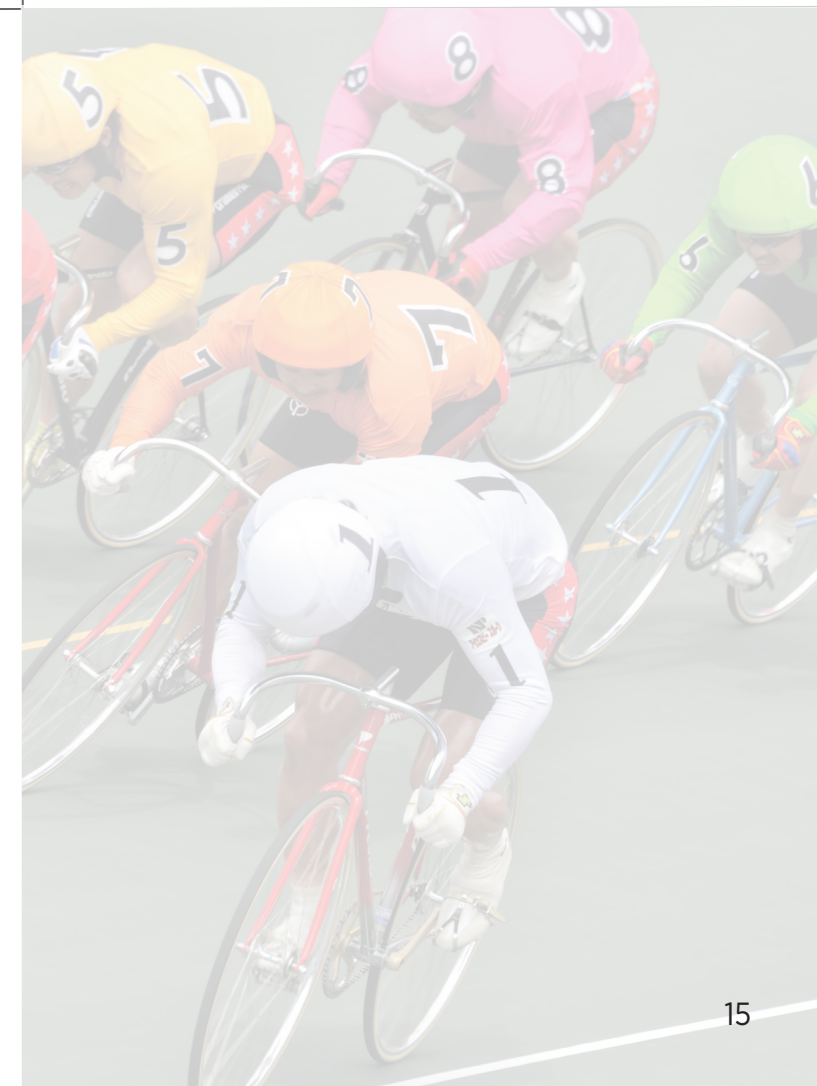

US-L / EZY SUPERIOR

is excellent for beginners, young riders with limited strength, and those with limited flexibility looking to ride with clipless pedals. MKS's unique split binding system provides a stable hold while clipped in, yet requires minimal release and engagement force. Includes Look Keo compatible cleats.



BODY	STEP	WEIGHT	COLOR
GFRP	Single Sided Clipless	290g Ezy Superior 345g	■ Black

US-S / EZY

is our SPD compatible clipless pedal. The MKS split binding system provides a stable hold while clipped in, yet requires minimal release and engagement force. Our design is excellent for beginners and those with limited flexibility. The detachable plastic cage helps build confidence when starting out with clipless pedals. Includes Shimano SPD compatible cleats.



BODY	STEP	WEIGHT	COLOR
Alloy	Double Sided Clipless	433g Ezy 503g	■ Silver

GRAFIGHT-XX

is a reissue of one of the earliest pedals on the market using Synthetic Fiberglass Resin, which we proclaimed to be nearly half of the weight of an aluminum alloy pedal while being twice as ridged and strong. Ideal for E-bikes!

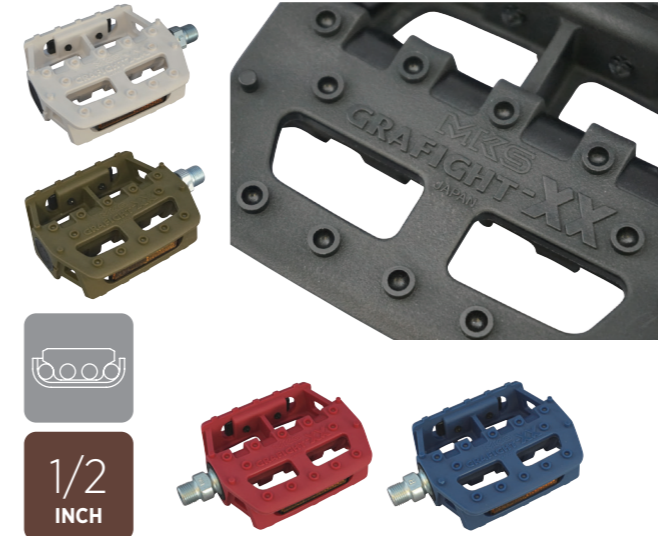

BODY	STEP	WEIGHT	COLOR
GFRP	Double Sided	440g	■ See Detail

BM-7

is a reissue of one of our most popular BMX designs from 1979. The one-piece wrap-around cage features an aggressive tooth profile with a slight concave design to help keep your foot centered.



BODY	STEP	WEIGHT	COLOR
Alloy	Double Sided	366g	■ See Detail

MKS FOLDING

FD-7

is a strong alloy pedal that uses a single action for quick and easy folding. The FD-7 will keep you moving quickly both on and off of the bike. Featuring integrated reflectors and a semi-aggressive tooth pattern this pedal works as a great city pedal.



BODY	STEP	WEIGHT	COLOR
Alloy	Double Sided	487g	■ Silver ■ Black



MT-LITE

is our classic mountain bike pedal that is also excellent for all riders who are tough on their equipment. Featuring a steel cage with wide teeth and rounded corners to prevent accidental scrapes. The steel cage provides excellent strength against bashing while our alloy pedal body saves weight when compared to an all steel pedal.



BODY	STEP	WEIGHT	COLOR
Alloy	Double Sided	439g	■ Silver ■ Black

XC-III

Suntour's XC-II, a popular MTB flat pedal in the past, has been reproduced in collaboration with Blue Lug. Excellent for MTB, BMX. Also great for track bikes and commuters. *Exclusive distribution by BlueLug in Japan and the USA.



BODY	STEP	WEIGHT	COLOR
Alloy	Double Sided	400g	■ Silver ■ Black

PB-50

is a basic unicycle pedal that is also popular for comfort bikes.



BODY	STEP	WEIGHT	COLOR
Plastic	Double Sided	386g	☐ White

RUNBER-X

is our indoor unicycle pedal. The Runber-X features rounded rubberized corners to protect indoor surfaces and small plastic pins for grip. The Runber-X is made of plastic and has a 9/16th thread spindle. *Please note this does not have a reflector as it's made for competition*



BODY	STEP	WEIGHT	COLOR
Plastic	Double Sided	312g	■ Grey ■ Black

UX-D / EZY

is a standard entry pedal that is light and cost-effective. Available also with Ezy version for easy removal and attachment.



BODY	STEP	WEIGHT	COLOR
Plastic	Double Sided	249g Ezy 300g	■ Black

PANAMAX / EZY SUPERIOR

It has the largest tread surface of our plastic pedals. This pedal has an elastomer grip sheet on the surface.

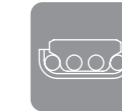

BODY	STEP	WEIGHT	COLOR
Plastic elastomer	Double Sided	378g Ezy Superior 441g	■ Black

G-6000

is one of our basic pedals, great for all around usage and very popular with Unicycle riders. This pedal is larger in length, width, and height than an average pedal. The G-6000 has a high tooth profile to provide great grip, and has a built in reflector.



BODY	STEP	WEIGHT	COLOR
Plastic	Double Sided	386g	■ Black

3000S / 3000R

is a reissue of one of our first pedals. We designed the Type 3000 to be used on a popular style of utility bicycles at the time called a Roadster, but we have found it at home not only on classic bikes, but also on Rat Rods, Beach Cruisers, Commuters, and leisure bikes. *The 3000R has a reflector, while the 3000S does not.*



BODY	STEP	WEIGHT	COLOR
Steel rubber	Double Sided	3000S 706g 3000R 703g	■ Black

PB-370

is a basic low-cost pedal featuring built-in reflectors. The plastic double-sided pedal body is impact resistance.



BODY	STEP	WEIGHT	COLOR
Plastic	Double Sided	330g	■ Black

PB-430

These are standard plastic pedals that are perfect for old-fashioned city riding.



BODY	STEP	WEIGHT	COLOR
Plastic	Double Sided	311g	☐ White

TOE CLIP STEEL



MATERIAL	SIZE
Steel	SS, S, M, L, LL

TOE CLIP STEEL DEEP



MATERIAL	SIZE
Steel	M, L, LL

TOE CLIP ALLOY



MATERIAL	SIZE
Alloy	S, M, L

HALF CLIP



MATERIAL	SIZE
Steel	1 size

HALF CLIP DEEP



MATERIAL	SIZE
Steel	1 size

QUARTER CLIP



MATERIAL	SIZE	COLOR
Resin Coated Steel	1 size	Black

TOE CLIP STEEL W/ LEATHER



MATERIAL	SIZE	COLOR
Steel	S, M, L	Brown

TOE CLIP STEEL DEEP W/ LEATHER



MATERIAL	SIZE	COLOR
Steel	M, L, LL	Brown

TOE CLIP ALLOY W/ LEATHER



MATERIAL	SIZE	COLOR
Alloy	S, M, L	Brown

HALF CLIP W/ LEATHER



MATERIAL	SIZE	COLOR
Steel	1 size	Black Brown

HALF CLIP DEEP W/ LEATHER



MATERIAL	SIZE	COLOR
Steel	1 size	Black Brown

MT250



MATERIAL	SIZE
Nylon	M, L

TOE CLIP STEEL DEEP TWIN

for double straps



MATERIAL	SIZE
Steel	M, L, LL

measured figures (unit: mm)

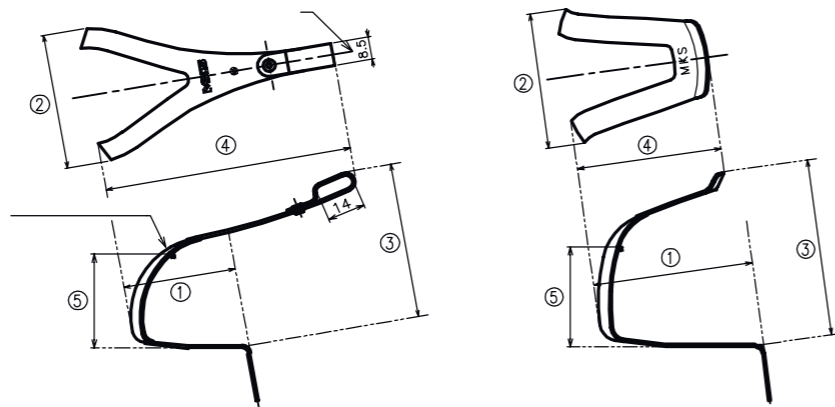

Toe Clip Steel (Cr plated)					
size	①	②	③	④	⑤
SS	41	51	58	90	31
S	46	51	61	94	31
M	51	51	70	104	37
L	62	51	72	110	37
LL	72	51	80	125	37
Toe Clip Alloy					
S	46	51	61	94	31
M	51	51	70	104	37
L	62	51	72	110	37
Toe Clip Steel Deep (Cr plated)					
M	51	51	74	95	42
L	62	51	78	103	42
LL	72	51	82	114	42

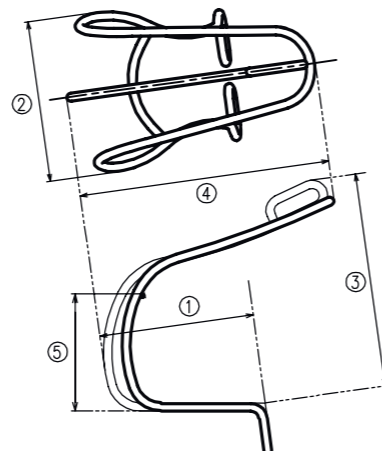

CAGE CLIP



MATERIAL	SIZE
Stainless Steel	S, M, L

CAGE CLIP HALF



MATERIAL	SIZE
Stainless Steel	M, L

CAGE CLIP QUARTER



MATERIAL	SIZE
Stainless Steel	M, L

Toe Clip Adjustable (steel-Cr plated)					
size	①	②	③	④	⑤
S~L	46~62	51	61~72	94~110	
Half Clip (steel-Cr plated)					
L	60	58	61	70	28
Half Clip Deep (steel-Cr plated)					
L	60	58	76	53	42
Quarter Clip (steel-Cr plated/resin coated)					
L	63.7	58	64.2	26.4	40
Cage Clip (stainless steel)					
S	44.8	58	77.5	88.2	41.5
M	52.8	58	79	95.8	41.5
L	65.7	58	83	107.5	41.5

Cage Clip Half (stainless steel)					
size	①	②	③	④	⑤
M	52.8	58	64.3	51.8	41.5
L	65.7	58	68.1	68.7	44.5
Cage Clip Quarter (stainless steel)					
M	46	58	61.8	28.2	42.2
L	58.9	58	63.7	28.2	42.2
MT-250 (plastic)					
M	71	63	98	90	
L	73	68	106	100	

FIT -α SPORTS



MATERIAL	STRAPS	LENGTH	WIDTH
Suede Leather Stainless Buckle	Single	412mm	25mm at buckle 12.5mm at strap

FIT -α SPORTS 2 BUCKLE



MATERIAL	STRAPS	LENGTH	WIDTH
Suede Leather Stainless Buckle	Double	412mm	53mm at buckle 12.5mm at strap

FIT -α FIRST



MATERIAL	STRAPS	LENGTH	WIDTH	COLOR
Nylon Stainless Buckle	Single	420mm	13mm	Black Grey Yellow Pink Green

FIT -α SPIRITS



MATERIAL	STRAPS	LENGTH	WIDTH
Genuine Leather Stainless Buckle	Single	400mm	12.5mm

FIT -α SPIRITS 2 BUCKLE



MATERIAL	STRAPS	LENGTH	WIDTH
Genuine Leather Stainless Buckle	Double	400mm	40.5mm at buckle 12.5mm at strap

MC-2



DESCRIPTION
Adds a classic cleat to modern 3 hole cycling shoes. Allows extremely secure engagement between classic road pedals and modern shoes. MKS products for ROYAL NUEVO & SUPREME

CA-MKS



Sold as a set

MATERIAL	SIZE
Stainless Steel	Hub Spindle 10mm Dropout Thickness 5mm

CA-MX14



Sold Singly

MATERIAL	SIZE
Stainless Steel	Hub Spindle 14mm Dropout Thickness 8mm

CA-MX10



Sold Singly

MATERIAL	SIZE
Stainless Steel	Hub Spindle 10mm Dropout Thickness 8mm

REFLECTOR SET



MATERIAL
Plastic 4 pieces per set Mounting bolts and nuts included

BEE BUTT

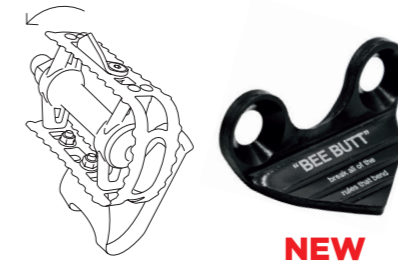

MATERIAL
Alloy Mounting bolts and nuts included

SPIN-2

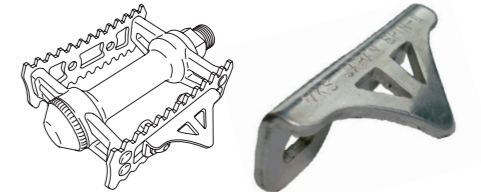

MATERIAL
Alloy Mounting bolts and nuts included

CAP SPANNER



MATERIAL	SIZE
Steel	108mm long 2 mm thick

PEDAL SPANNER



MATERIAL	SIZE
Steel	165mm long 3.2 mm thick

CRANK SPACERS



MATERIAL
Steel 4 pieces per set

US-S

SPD Compatible



US-L

Keo Compatible



MC-1

Plastic Cleat for EX-A Only



MC-3

Alloy Cleat for EX-A Only



US-A

Time ATAC Compatible



EZY ADAPTER SET













EZY SUPERIOR ADAPTER SET



EZY STOPPERS







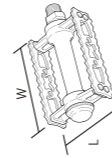





Model	FD-7 WIDE	Pretzel	SYLVAN GORDITO	Seahorse	SYLVAN ROAD	SYLVAN TOURING	SYLVAN TRACK	SYLVAN STREAM	SYLVAN ROAD NEXT	SYLVAN TOURING NEXT	SYLVAN TRACK NEXT	SYLVAN STREAM NEXT
		 →P4	 →P4	 →P5	 →P5	 →P6, 7, 8	 →P6, 7, 8	 →P6, 7, 8	 →P6, 7, 8	 →P6, 7, 9	 →P6, 7, 9	 →P6, 7, 9
Color	Silver/Black	Silver/Black	Silver/Black	Silver/Black	Silver/Black	Silver/Black	Silver/Black	Silver/Black	Silver/Black	Silver/Black	Silver/Black	Silver/Black
Body	Alloy	Alloy	Alloy	Alloy	Alloy	Alloy	Alloy	Alloy	Highly Polished Alloy	Highly Polished Alloy	Highly Polished Alloy	Highly Polished Alloy
Cage Plate	Alloy Cast	Alloy Cast	Alloy Anodized	—	Alloy Anodized	Alloy Anodized	Alloy Anodized	Alloy Anodized	Alloy Anodized	Alloy Anodized	Alloy Anodized	Alloy Anodized
Bearing	Cup & Cone	Cup & Cone	Cup & Cone	Cup & Cone	Cup & Cone	Cup & Cone	Cup & Cone	Cup & Cone	Triple sealed bearing	Triple sealed bearing	Triple sealed bearing	Triple sealed bearing
Step Area	Double sided	Double sided	Double sided	Double sided	Single sided	Double sided	Single sided	Double sided	Single sided	Double sided	Single sided	Double sided
Size ※1	W92 X L110	W94 X L114	W94 X L85	W72 X L93	W99 X L61	W94 X L63	W80 X L61	W79 X L61	W99 X L61	W94 X L63	W80 X L61	W79 X L61
Ezy / Ezy Superior Lineup	—	Ezy Superior optional	—	—	—	—	—	—	Ezy Superior optional	Ezy Superior optional	Ezy Superior optional	Ezy Superior optional
ToeClip	X	X	○	X	◎	○	◎	○	◎	○	◎	○
Reflector	◎	◎	○	◎	X	○	X	○	X	○	X	○
Weight of pair ※2	562g	530g(593g)	430g	340g	360g	391g	343g	343g	330g(385g)	338g(393g)	318g(373g)	318g(373g)

※1
Size
W:width(mm)
L:length(mm)



※2
○ indicates Ezy or Ezy-Superior weight of a pair.

Model	ALLWAYS	LAMBDA	GAMMA	RMX	COMPACT	CYGMA	CT-LITE	IC-LITE	PROMENADE	UB-LITE	ESPRIT	MT-E
		 →P10	 →P10	 →P10	 →P10	 →P11	 →P11	 →P11	 →P11	 →P12	 →P12	 →P12
Color	Silver/Black	Silver/Black	Silver/Black	Cosmic-silver	Grey/Black	Silver	Silver/Black	Silver/Black	Titanium/Black	Silver/Black	Titanium	Silver/Black
Body	Alloy	Alloy	Alloy	Alloy	CNC milled Extruded Alloy	Alloy	Alloy	Alloy	Alloy	Alloy	Alloy	Alloy
Cage Plate	—	Alloy Cast	Alloy Cast	—	—	—	—	—	Alloy Anodized	Alloy Anodized	Alloy Anodized	—
Bearing	Triple sealed bearing	Cup & Cone	Cup & Cone	Cup & Cone	Sealed & Bushing	Sealed & Bushing	Cup & Cone	Cup & Cone	Cup & Cone	Cup & Cone	Cup & Cone	Cup & Cone
Step Area	Double sided	Double sided	Double sided	Double sided	Double sided	Double sided	Double sided	Double sided	Double sided	Double sided	Double sided	Double sided
Size ※1	W84 X L110	W78 X L119	W78 X L118	W90 X L86	W75 X L67	W73 X L64	W93 X L66	W93 X L67	W85 X L64	W93 X L64	W94 X L68	W102 X L64
Ezy / Ezy Superior Lineup	Ezy Superior optional	Ezy Superior optional	Ezy Superior optional	—	Ezy optional	Ezy optional	—	—	Ezy optional	Ezy optional	Ezy Superior optional	Ezy optional
ToeClip	X	X	X	X	X	○	○	X	○	○	○	◎
Reflector	X	◎	◎	◎	○	○	○	◎	○	○	○	○
Weight of pair ※2	381g(436g)	420g(483g)	450g(513g)	384g	233g(303g)	240g(310g)	343g	365g	305g(355g)	314g(365g)	352g(415g)	323g(374g)

※1
Size
W:width(mm)
L:length(mm)

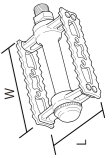

※2
○ indicates Ezy or Ezy-Superior weight of a pair.

